



CREATEUR DE NOUVELLES MOBILITES

# ESTACA LAB

## ASSOCIATE PROFESSORS & PH.D. STUDENTS

Groupe ISAE 

## Two research Departments

- ❑ Department of Energy and Embedded Systems Department
- ❑ Department of Mechanical and Environmental Engineering

## Research Topics

- ❑ Air quality and depollution
- ❑ (Bio)Composites materials and added functions
- ❑ Smart Transports, connected and safe, autonomous transport
- ❑ Use of innovated transports and new mobilities

## Involvement in center of excellence and local government

- ❑ 5 centers of excellence: Astech, Moveo, ID4CAR, Systematic, EMC2
- ❑ Founding member of ITE VEDECOM



## Department of Mechanical and Environmental Engineering

⇒ Head of Department: *CUVELIER Philippe*

LAST NAME	FIRST NAME	POSITION
AMENINI	Federico	Ph.D. Student
BEDRICI	Nacera	Associate Professor
BROCAIL	Julien	Associate Professor
CHAUVIN	Michael	Associate Professor
CUVELIER	Philippe	Associate Professor
DURAND	Antoine	Ph.D. Student
FOKOUA	Georges	Associate Professor
HAGGUI	Mondher	Ph.D. Student
GILLET	Stephane	Associate Professor
JENDLI	Zouhaier	Associate Professor
KEITA	Namamoudou	Ph.D. Student
MEHEL	Amine	Associate Professor
MURZYN	Frédéric	Associate Professor
RODRIGUEZ	Romain	Ph.D. Student
SAGOT	Benoît	Associate Professor
TRUONG HOANG	Thuy-Quynh	Associate Professor
WALRICK	Jean-Christophe	Associate Professor

### Staff

LAST NAME	FIRST NAME	POSITION
DURAND	Michelle	Administrative Staff
FAUX	Franck	Technician
JAMBON	Gérard	Technician
LAFARGE	Victor	Technician
PIOGER	Sandrine	Administrative Staff

More information: <https://www.estaca.fr/en/>

## Department of Energy and Embedded Systems

⇒ Head of Department: *LAROUCI Cherif*

LAST NAME	FIRST NAME	POSITION
ALLAOUI	Hamza	Ph.D. Student
ASSEM	Houria	Ph.D. Student
AZIB	Toufik	Associate Professor
BABIN	Anthony	Associate Professor
BARBEDETTE	Bertrand	Associate Professor
BENDJEDIA	Bachir	Ph.D. Student
BENTERKI	Abdelmoudjib	Ph.D. Student
BOUKHARI	Mohamed	Ph.D. Student
BOUKHNIFER	Moussa	Associate Professor
CESCHIA	Adriano	Ph.D. Student
CHAIBET	Ahmed	Associate Professor
DEGAA	Laïd	Ph.D. Student
JUDALET	Vincent	Associate Professor
KHAMMASSI	Montassar	Pd.D. Student
KENFRI	Fouad	Associate Professor
LAROUCI	Chérif	Associate Professor
LATRECH	Chedia	Ph.D. Student
LESERF	Patrick	Associate Professor
MCHAREK	Mehdi	Ph.D. Student
MENG	Jianwen	Ph.D. Student
MHANNA	Hussein	Ph.D. Student
PIOGER	Sandrine	Administrative Staff
RIZOUG	Nassim	Associate Professor
RKHISSI KAMMOUN	Yosra	Ph.D. Student
SAADI	Yakoub	Ph.D. Student
SAUDRAIS	Sebastien	Associate Professor
SEHAB	Rabia	Associate Professor
SEHIT	Mehdi	Ph.D. Student
SOUBRA	Hassan	Associate Professor
YACEF	Fouad	Ph.D. Student

## ADMINISTRATIVE STAFF

### **Sandrine PIOGER**

West Campus  
sandrine.pioger@estaca.fr  
+33(0)2 43 59 47 14

### **Michelle DURAND**

Paris Saclay Campus  
michelle.durand@estaca.fr  
+33(0)1 76 52 11 20



## TECHNICAL STAFF

### **Franck FAUX**

Department of Mechanical and Environmental Engineering  
Paris Saclay Campus  
franck.faux@estaca.fr  
+33(0)1 76 52 11 23

### **G rard JAMBON**

Department of Energy and Embedded Systems  
West Campus  
gerard.jambon@estaca.fr  
+33(0)2 43 59 53 90

### **Victor LAFARGE**

Department of Mechanical and Environmental Engineering  
West Campus  
victor.lafarge@estaca.fr  
+33(0)2 43 59 53 90



Department of Mechanical and  
Environmental Engineering

**ASSOCIATE PROFESSORS**

SM100  
UNION TEST  
MACHINE (U)

# Department of Mechanical and Environmental Engineering

Nacera BEDRICI, Associate Professor in composite materials, ESTACA'LAB, ESTACA, West Campus, PhD, University of Compiègne (2002)



Characterization of composite materials, propagation of acoustic waves, detection of damage in materials

Contact : nacera.bedrici@estaca.fr  
+33. (0)2 4359 4729

## Research topics :

Acoustic wave propagation (semi analytical method, boudary element method), lamb wave, interface wave (Rayleigh, Stoneley), interaction of acoustic wave with the different defect, acoustic emission

→ Experimental test for charactezation of composite materials

## Examples of past projects :

- Defi composite : « Set up a "CHALLENGE" toolbox in order to take full advantage of the use of composites on a structure»
- ECOINGBOX (ECO composite WING BOX) : « design, manufacture and validation of a composite business jet box demonstrator » with Daher, Coriolis...
- Smart composite : integration of carbon nanotubes

## Ongoing research projects :

Fatigue damage characterization and modelling on thermoplastic composite reinforced by continuous fibers (PhD thesis)

Characterization of piezoelectric foam

## Collaborations (academic, institutional and industrial):

- Universities of Compiègne, Le Mans, MINES ParisTech, Nantes ...
- Cooper standart, ODAXO, IPC ...

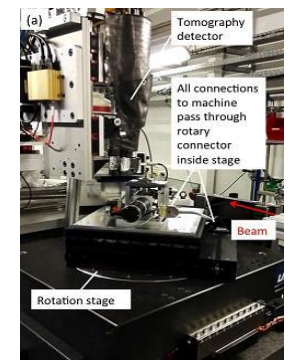
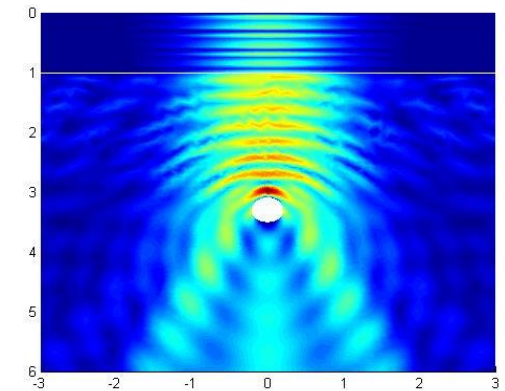

Julien BROCAIL, Associate Professor , ESTACA West Campus, LAVAL

Laboratory of Composite Materials and Structures

Contact :    julien.brocail@estaca.fr  
              +33 (0)2 43 59 47 35



## Biographical note:

Julien BROCAIL received his PhD in Mechanical Engineering from the University of Valenciennes in 2009. After receiving the Ph.D. degree, he joined MEDYSYS, an engineering company specializing in mechanical computation and numerical modeling.

Since 2012, he is part of the department of Mechanical Engineering research center: ESTACA'LAB at ESTACA engineering school, France. He joined ESTACA'LAB as an associate professor in the Laboratory of composite materials and structures. His main research interest includes damping wave propagation in periodic composite panels, band gaps in metamaterial plates, inverse identification of stiffness parameters from the local dynamic equilibrium, dynamic recrystallization under critical friction conditions.

## Equipment and tools:

- Abaqus, Comsol Multiphysics, Hyperworks, PamCrasch, ...
- Universal testing machine, Dynamic and Fatigue hydraulic systems, Drop Test, ...
- High speed camera, Digital Image Correlation, ...
- Shaking table, Laser Doppler Vibrometer, ...

## Collaborations (industrial, academic and institutional):

- Valeo, Gruau, Rapido, Segula, Altran, IPC, ...
- LAMIH, IRDL, LAUM, ...
- EMC2, ID4CAR, LMT, ...

# Department of Mechanical and Environmental Engineering

Dr Michaël CHAUVIN, Associate Professor in Composites Materials, ESTACA West Campus, LAVAL

Composites materials in transportation systems (automotive, aeronautical and railways)

Contact : michael.chauvin@estaca.fr  
+33. (0)2 4359 4743  
<https://www.estaca.fr/michael-chauvin/>



## Research topics :

- Crashworthiness, damage, biocomposite, materials behaviour, coupling manufacturing process / structure ;
- Experimental investigations ;
- Digital Image Correlation, Acoustic Emission Testing, Environmental test chamber ;
- Fatigue, dynamic and universal testing systems, testing systems (50-150kN), Drop Test.

## Examples of past projects :

- Mechanical behaviour and damage process in the composite flax/epoxy with Kraft plies ;
- Study of process parameters on microstructural and mechanical properties for unidirectionnal flax/PA11 composite ;
- Mechanical impact and post-impact behavior of an eco-composite ;
- Energy absorption capacity of flax fiber reinforced epoxy tube by filament winding.

## Ongoing research projects :

- Modeling the behavior of the mechanical and vibro-acoustic properties of an eco-composite ;
- Energy absorption capacity of a hybrid composite tubular structure by filament winding ;
- Behavior of shock-absorbing structural part for nuclear waste transport systems.

## Collaborations (academic, institutional and industrial):

- Institut Pprime, Institut Recherche Dupuy De Lôme, ...
- AREVA, Rapido, Plasticon Composites, ...

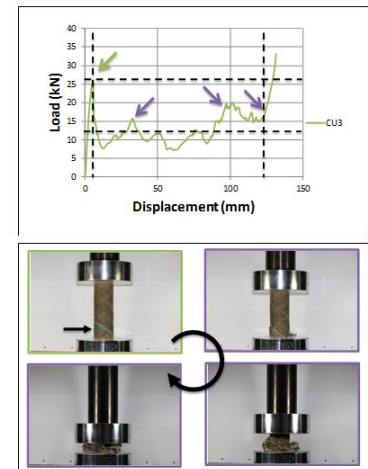

Fig. 1: Crashworthiness of flax fiber reinforced epoxy tube by filament winding

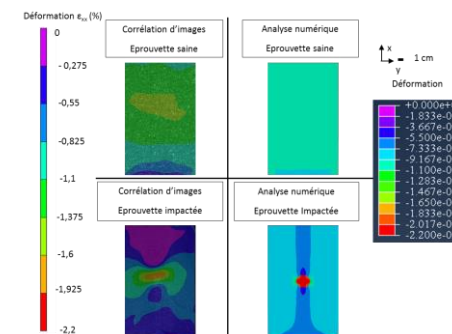

Fig. 2: Strain field on a flax/PA11 composite plate (experimental/simulation)



# Department of Mechanical and Environmental Engineering

**Philippe CUVELIER : Associate Professor in Acoustics & Vibrations, Head of department of Mechanical and Environmental Engineering**



Contact: philippe.cuvelier@estaca.fr  
<https://www.estaca.fr/philippe-cuvelier/>  
+33 (0) 1 76 52 11 18

## Research topics:

- Acoustic imaging
- Acoustic design of resonators to reduce the noise
- Structure Dynamics

## Example of projects:

- Acoustic design of resonators to reduce the noise level in a cabin
- Modelling of the vibratory behaviour of a wire rope spring by using the Dahl model with variable parameters
- Reduction of the first torsional mode of a structure by a gyroscopic damper
- O2M(mechatronic modeling tools)



## Ongoing research project:

- Infiltration of pollutant in car cabins (funded by ADEME)

## Industrial collaborations:

- PSA, SOCITEC, Hutchinson Paulstra, MGI COUTIER, VALEO, JOHNSON CONTROL, BOSCH

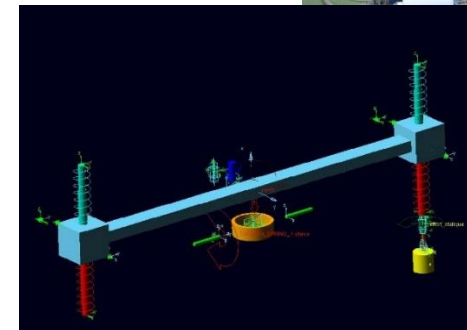

**Georges FOKOUA, Associate Professor**

**Air Quality and Depollution in Transportation Systems Laboratory (automotive, aeronautical and railways)**

Contact : [georges.fokoua@estaca.fr](mailto:georges.fokoua@estaca.fr)  
+33. (0) 1 76 52 12 05

## Biographical note:

**Georges Fokoua** received his Ph.D. in Multiphase Flow Dynamics from the University of Western Brittany (Brest – France) in 2013. He has been studying bubbly flows and particles in turbulence employing experimental (PIV and optical probes) and, both Eulerian and Lagrangian approaches. He also investigated bubbly drag reduction by combining global and local measurements. Since 2016, he is an associate professor in the Air Quality and Depollution in Transportation Systems Laboratory at ESTACA. He is mainly interested by pollutant measurements, multiphase flow modelling and studying interaction between turbulent and dispersed phase structures such as: steam (cavitation), gas (micro bubble injection) and aerosols pollutants from transport.

## Equipment and Tools:

- PIV, LDV, Aerosol generators and granulometers
- Ansys Fluent, Comsol Multiphysics, MATLAB

## Collaborations (industrial, academic and institutional):

- PSA, Valeo, SNCF, Ariamis, Dassault, Airbus Defense and Space, Mecaplast, Addair...
- Universities of Nancy, Paris Sud, Paris Saclay, Rouen, Bamako (Mali), Thessaloniki (Greece), Southern of California (USA), Windsor (Canada),...
- Ifsttar, Airparif...

Stéphane GILLET, Associate Professor in Material and Mechanics, ESTACA'LAB, ESTACA, West Campus,  
PhD Student, Mines de Paris

Material and Mechanics in transportation systems (automotive, aeronautical and railways)

Contact : [stephane.gillet@estaca.fr](mailto:stephane.gillet@estaca.fr)  
+33. (0)2 4359 4742



## Research topics :

- Multiscale Mechanical Experiment
- Multiscale Mechanical Modeling

## Examples of past projects :

- Thermoplastic composites reinforced with continuous fibers (DYNAFIB Project)
- Composite Chassis dimensioning (DEFI Composite Project)
- Smart composite : conductivity, electromagnetic shielding (PHD Mohcine Hassard), self healing

## Ongoing research projects :

- Fatigue damage characterization and modelling on thermoplastic composite reinforced by continuous fibers PHD in progress 2016-2020

## Collaborations (academic, institutional and industrial):

- Ecole des Mines de Paris, IRDL, INSA Rennes, UTC
- EMC2, ID4Car...
- Cooper Standard, Renault, PSA, 3M0, Coriolis Composites, IPC, compositic...

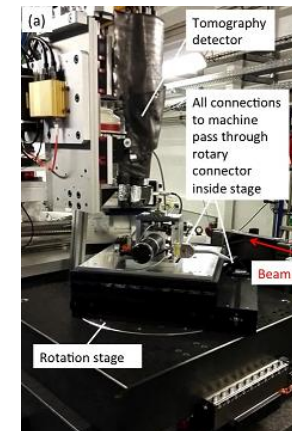

Fig. 1: In-situ fast tomography device (Ecole des Mines de Paris)

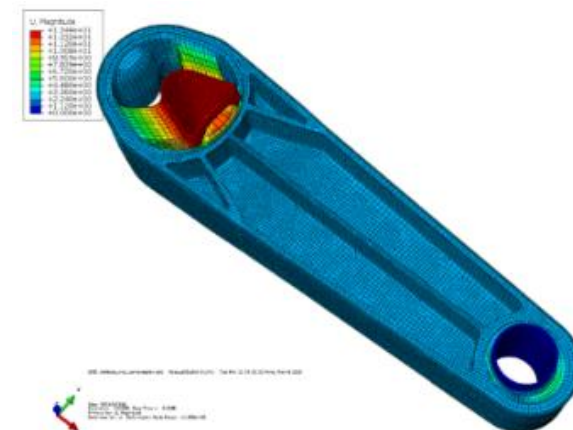

Fig. 2: DynaFib Torque rod Modeling

Zouhaier JENDLI, Ph.D. – Associate Professor in Mechanics and Materials, ESTACA, West Campus

Innovative Materials and Composite Structures (Automotive, Aeronautical and Railways)

Contact : [zouhaier.jendli@estaca.fr](mailto:zouhaier.jendli@estaca.fr)

+33. (0)2 43 59 47 21

[https://www.researchgate.net/profile/Zouhaier\\_Jendli](https://www.researchgate.net/profile/Zouhaier_Jendli)



## Biographical note :

Dr. Zouhaier JENDLI is associate professor at ESTACA engineering school since 2011. Previously, he was research and development engineer of composite materials in automotive transportation. He received a Ph.D. in mechanics and materials from the Ecole Nationale Supérieure d'Arts et Métiers, ENSAM of Paris in 2005. His current research interests includes modelling, experimentation and optimisation of composites mechanical behaviour, multi-scales approach, multi-constraints and dynamic loading, eco-composites in structural design, smart materials and structures.

## Examples of industrial and research projects :

- Project **MATIERES** (development of bio-based materials) :  
Manufacturing and mechanical characterization of a bio-based composite sandwich structure. Ph.D. thesis,  
Multi-scale analysis of the mechanical behaviour of an flax-Elium eco-composite. Ph.D. thesis,  
Flax fibre composite for vibration damping design. Master thesis,
- Project **CIM** (Structural composite behaviour for railways applications),
- Project **Hutchinson and Paulstra** :  
Characterization of the mechanical behaviour of thermoplastic composites under dynamic loading. Postdoctoral Research fellow,
- Project **DEFI Composites** (Composite chassis dimensioning),
- Project **SMC** : Multi-scale analysis and modelling of the mechanical behaviour of SMC composites under dynamic loading. Ph.D. thesis,

## Collaborations (academic, institutional and industrial):

- Université du Maine, ENSAM Paris and Angers, ENIS Sfax, ENSIT Tunis,
- EMC2, INRA,
- Faurecia, CIM SNCF, FIMALIN, ARKEMA, Hutchinson, Paulstra, CEMCAT / IPC Laval, CTTM,

**Amine MEHEL, Associate Professor**

**Air quality and Depollution in transportation systems Laboratory (automotive, aeronautical and railways)**

Contact : amine.mehel@estaca.fr  
+33. (0) 1 76 52 11 43



## **Biographical note:**

Amine Mehel received his PhD in Multiphase Flows Dynamics from the University of Nantes and Ecole Centrale of Nantes in 2006. He is an associate professor in the Air Quality and Depollution in transportation systems Laboratory at Aerospace and Automotive College of engineering (ESTACA). His main research interest includes the pollutant transport and dispersion in interactions with Flow turbulence, Pollutant Characterization and Measurements, nanoparticles dynamics modelling. Multiphase Flows CFD simulations.

## **Equipment and Tools:**

- PIV, LDV, Aerosol generators and granulometers
- Ansys Fluent, Matlab

## **Collaborations (industrial, academic and institutional):**

- PSA, Valeo, SNCF, Ariamis, Dassault, Airbus Defense and Space, Mecaplast, Addair...
- Universities of Nancy, Paris Sud, Paris Saclay, Rouen, Bamako (Mali), Thessaloniki (Greece), Southern of California (USA), Windsor (Canada),...
- Ifsttar, Airparif...

Frederic MURZYN, Associate Professor in Fluid Mechanics, ESTACA'LAB, ESTACA, West Campus, PhD, University of Caen (2002)



Air quality and Depollution in transportation systems (automotive, aeronautical and railways)

Contact : frederic.murzyn@estaca.fr  
+33. (0)2 4359 4715 - <https://www.estaca.fr/frederic-murzyn.html>

## Research topics :

- Wake flows, turbulence, multiphase flows, pollutant dispersion (particles), bluff bodies, fluid/structure interaction, infiltration of solid and gaseous pollutants
- Experimental investigations (wind tunnels) and on-board measurements
- LDV/PIV, pressure sensors, particle generators/counters, Ahmed bodies, grid-generated turbulence

## Examples of past projects :

- Air quality in car cabin (funded by Renault)
- Characterization of a grid-generated turbulence in wind tunnel
- Concentration fields of particles in the wake of a vehicle

## Ongoing research projects :

- Infiltration of pollutant in car cabins (funded by ADEME)
- Experimental study of the dispersion of nanoparticles in the wakes of Ahmed bodies (cars), PhD thesis
- Numerical study of the dispersion of nanoparticles in the wakes of obstacles (cylinders and cars), PhD thesis
- Dispersion of particles issued from brakes: application to train in enclosed stations

## Collaborations (academic, institutional and industrial):

- Universities of Thessaloniki, Rouen, Nancy, Windsor, Southern California...
- Ifsttar, Airparif...
- Renault, PSA, SNCF, Ariamis, Denso, Naturality...

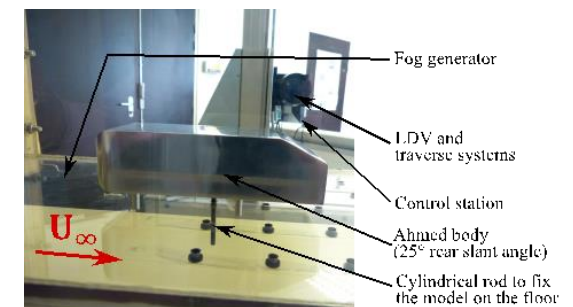

Fig. 1: Experimental set-up in wind tunnel

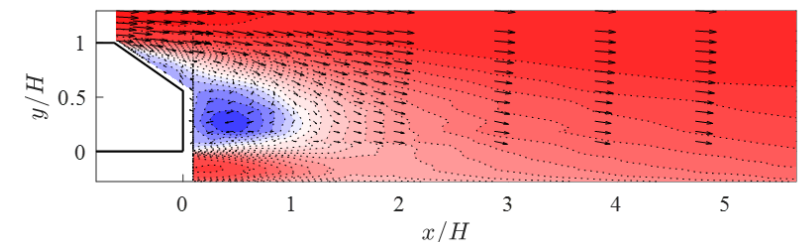

Fig. 2: Mean streamwise velocity fields in the wake of an Ahmed body (35°)

**Benoit SAGOT, Associate Professor**

**Air quality and Depollution in transportation systems Laboratory (automotive, aeronautical and railways)**

Contact : [benoit.sagot@estaca.fr](mailto:benoit.sagot@estaca.fr)  
+33. (0) 1 76 52 11 57



## **Biographical note:**

Benoit Sagot holds an Engineering degree from Ecole Nationale Supérieure d'Électricité et de Mécanique (Nancy), and he received his PhD in Aerosol Dynamic from the Compiègne University of Technology (Sorbonne University). He is an associate professor in the Air Quality and Depollution in transportation systems Laboratory at Aerospace and Automotive College of engineering (ESTACA). His main research interest includes the assessment of aerosol separation mechanism or systems, and the development of measurement methods for the aerosol pollutant characterization.

## **Equipment and Tools:**

- Liquid and solid aerosol generators. Optical particle counter, Cascade impactor (Andersen, ELPI, SMPS)
- Star ccm+, Matlab

## **Collaborations (industrial, academic and institutional):**

- PSA, Valeo, SNCF, Ariamis, Dassault, Airbus Defense and Space, Mecaplast, Addair...
- Universities of Nancy, Paris Sud, Paris Saclay, Rouen, Bamako (Mali), Thessaloniki (Greece), Southern of California (USA), Windsor (Canada),...
- Ifsttar, Airparif...

Thuy-Quynh TRUONG-HOANG, Associate Professor in mechanics of composite materials, ESTACA'LAB, ESTACA, West Campus

PhD, ENSMA- Poitiers (2004)

Functional Composite Structures -Biocomposites (automotive, aeronautical and railways)

Contact : thuy-quynh.truong-hoang@estaca.fr

+33. (0)2 4359 4730

<https://www.estaca.fr/quynh-truong-hoang/>



## Research topics :

- Biocomposites for semi-structural applications in transport: flax, hems fibers reinforced thermoplastic and thermoset polymers
- Experimental strain field measurement by DIC method, non destructif techniques : Acoustics emission, C-scan,
- Material characterization : microstructural analysis (DSC, DMA) , static and dynamics tests, vibration and damping measurement for materials and sandwich structures

## Examples of past projects :

- Impact and post-impact behaviour of Flax fiber/PA11 obtained by hot-pressing process
- Technical flax fiber composite for vibration damping design (funded by FiMaLin)
- Non-woven flax fiber reinforced polypropylene: mechanical properties in static and low velocity impact behaviours (collaboration with Eco-Technilin)
- Natural fibre reinforced new and recycled polypropylene for automotive parts (funded by ADEME)

## Ongoing research projects :

- Experimental study of bending impact test at high strain rate using VIC measurement
- Comparaison of mechanical and damping properties of flax fibers versus glass fibers reinforced composite
- Hygrothermal ageing influences on biocomposite

## Collaborations (academic, institutional and industrial):

- Pprime-ISAIE-ENSMA, LAUM-Maine University, GEM- IUT Saint Nazaire, Ho Chi Minh city University of Technology ...
- FiMaLin, EMC2
- Terre de lin, Arkema, Eco-technilin,



Fig. 1: Impact indentation of flax fiber/PA11 composite

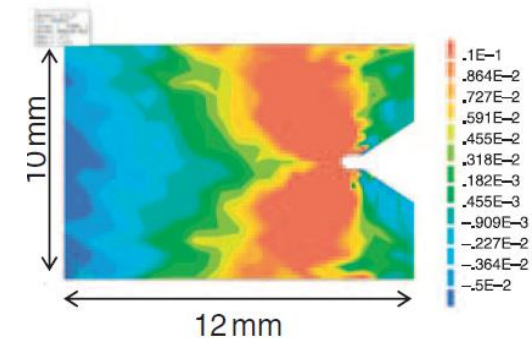

Fig. 2. DIC measurement of crack propagation in recycled polypropylene



# Department of Mechanical and Environmental Engineering

Jean Christophe WALRICK, Associate Professor in Solid Mechanics, ESTACA'LAB, ESTACA, West Campus, PhD, University of Valenciennes (1999)



Dynamique behaviour and crashworthiness for Multifunctional composite material and structures in transportation systems (automotive, aeronautical and railways),

Contact : [jean-christophe.walrick@estaca.fr](mailto:jean-christophe.walrick@estaca.fr) +33. (0)2 4359 4731 <https://www.estaca.fr/jean-christophe.walrick.html>

## Research topics :

- Mechanical behavior for composite structures under complex dynamic loading (experimental and numerical approaches)
- Improvement of electrical conductivity and Electromagnetic shielding for composite structure : electrical conductor system embedded inside composite and manufacturing process associated.
- Damage studies under mechanical loading : prediction of strength and damage evolution under environment (temperature and moisture)

## Examples of past projects :

- Influence of conductive fillers in mechanical behavior of composite fabric
- Optimisation of automotive composite structures under impact : pick-up vehicle floor (CSP Europe)

## Ongoing research projects :

- Development of impact sensor with piezo-resistive foam embedded in composite structure for transport application. (ODAXOS)
- Damage models development for long fiber layup composite with conductor under low impact (failure and delamination prediction) PhD –Thesis
- Sandwich structure test optimisation for bird-strike certification (HUTCHINSON)

## Collaborations (academic, institutional and industrial):

- Universities of Nantes, GEM...
- INSTA – Brest
- HUTCHINSON, AIRBUS GROUP, DCNS,



Fig. 1: Experimental set-up for droop test impact on composite

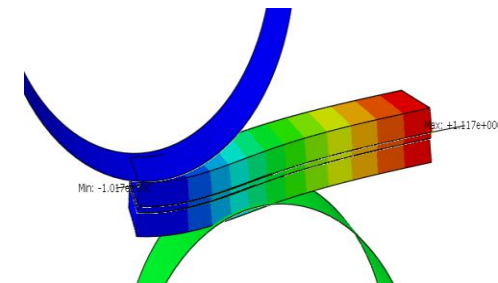
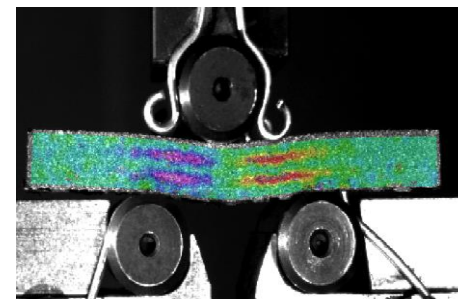

Fig. 2: Stress and damage concentration for conductor inside composite during bending test



Department of Mechanical and  
Environmental Engineering

**ONGOING PH.D. STUDENTS**

Antoine DURAND, PhD student in Fluid Mechanics, ESTACA'LAB, SQY Campus, SNCF Rolling Stock Engineering Centre, Le Mans



Particle dispersion from railway rolling stock at braking stage in underground train stations

Contact : antoine.durand@estaca.eu  
+33. (0)6 8596 8413

## Context :

- While braking, trains generate several metallic particles
- Confinement effect in underground train stations leads to high particle mass concentration rates
- Commuters and workers are exposed to particulate pollution with health impact and important economic costs

## Goals :

- Assess the wake flow of a typical suburban train during braking stage
- Investigate particle-flow interactions
- Characterise commuter and worker exposure to UFP issued from brakes

## Ongoing work :

- Lagrangian two-phase approach using RANS model and Eddy Interaction Model to assess the wake flow and particle dispersion by the turbulence
- Comparison/validation of CFD results with experiments (wake flows, particle dispersion)
- Make some recommendations for underground air quality improvement (ventilation, particles collecting devices, protection equipment, ...)

## Thesis supervision:

- Dr. Frédérique Larrarte, IFSTTAR (Principal advisor)
- Dr. Amine Mehel and Dr. Frédéric Muzyn, ESTACA'LAB (Associate advisors)
- Mr. Samuel Puech, SNCF (Associate advisor)

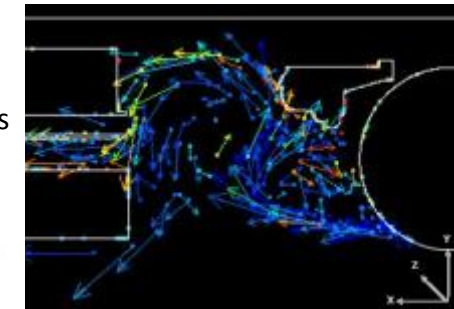

Fig. 1: Particle path at braking stage at the level of a trailer bogie (flow from right to left)

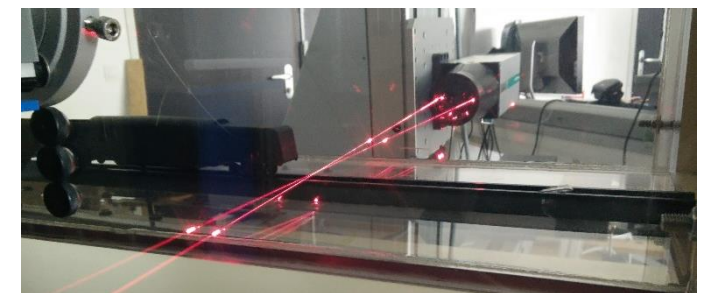

Fig. 2: Wind tunnel experimental setup with 2D-LDV measurement system

# Department of Mechanical and Environmental Engineering

Mondher HAGGUI, Ph.D. Student in Mechanics and Materials – ESTACA Laval / Université du Maine / ENIS Sfax Tunisia

Innovative Materials and Composite Structures (Automotive, Aeronautical and Railways)

Contact : mondher.haggui.etu@univ-lemans.fr

+33. (0)7 69 68 01 03

## Biographical note :

Mondher HAGGUI is a Ph.D. student at Le Mans Université with the collaboration of ESTACA engineering school and ENIS Sfax Tunisia. He received an engineering diploma in mechatronics from the national engineering school of Sousse ENISo, Tunisia in 2009. Actually, he is a technologist professor in mechanical department of the higher institute of technology in Kasserine, Tunisia.

## Research topics :

- Manufacturing and experimental characterization of eco-composite,
- Vibration and damping behaviour of flax fibres composite materials,
- Bio-composite multi-scale analysis.

## Examples of past projects :

- Delamination study of pultruded composite materials. Master thesis(ENISo)
- Fatigue and impact behaviour of natural composite. (ENIM),
- Mechanical and chemical extraction of natural fibres (ENIM),
- Design and manufacture of didactic system(SEA electronics).

## Collaborations (academic, institutional and industrial):

- ARKEMA, LAUM Le Mans, Université de Sfax Tunisia,

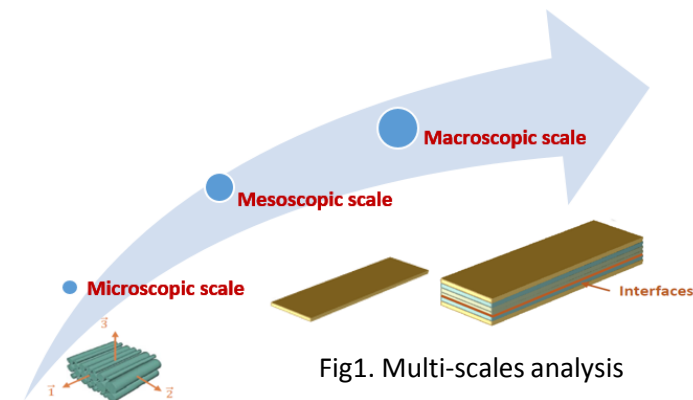

Fig1. Multi-scales analysis

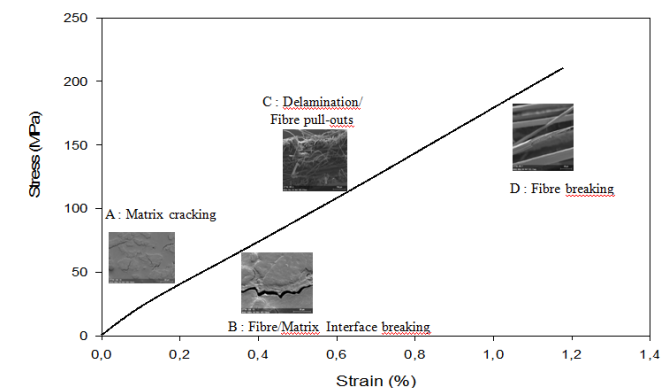

Fig2. Mechanical behaviour of bio-composite materials

Namamoudou Sidiki KEITA, PhD Student in Mechanics Energy, University of Lorraine (Nancy) and University of Bamako (Mali)

ESTACA Paris Saclay, 12 avenue Paul Delouvrier – RD 10, 78180 Montigny-le-Bretonneux - France

Contact : [namamoudou-sidiki.keita@estaca.fr](mailto:namamoudou-sidiki.keita@estaca.fr)  
+33. (0)1 76 52 11 43



## Research topics :

- Wake flows, turbulence, multiphase flows, pollutant dispersion (particles), bluff bodies, fluid/structure interaction, infiltration of solid and gaseous pollutants
- Experimental investigations (wind tunnels) and on-board measurements
- LDV/PIV, pressure sensors, particle generators/counters, Ahmed bodies, grid-generated turbulence

## Examples of past projects :

- Climate change, Heat waves
- Concentration fields of particles in the wake of cylinder
- Effects of brownian motion and the turbulence on the dispersion of nanoparticles

## Ongoing research projects :

- Experimental study of the dispersion of nanoparticles in the wakes of a cylinder and Ahmed bodies (cars)
- Numerical study of the dispersion of nanoparticles in the wakes of obstacles (cylinders and cars)

## Collaborations (academic, institutional and industrial):

- University of Lorraine (Nancy), University of Bamako (Mali).
- Ifsttar, Airparif

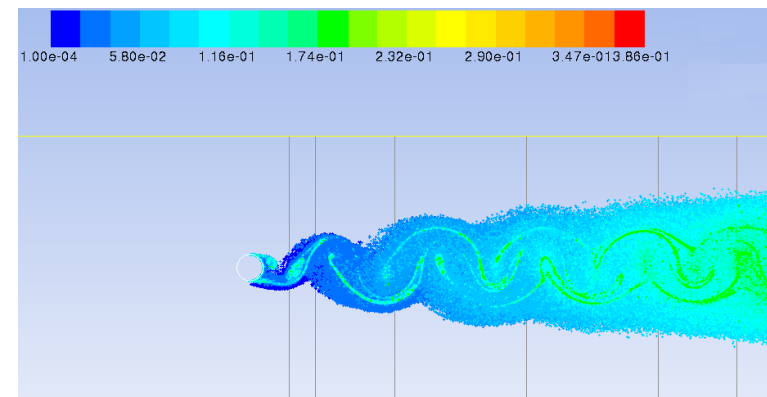

Fig. 1: Nanoparticles tracks colored by their residence in the wake of a cylinder

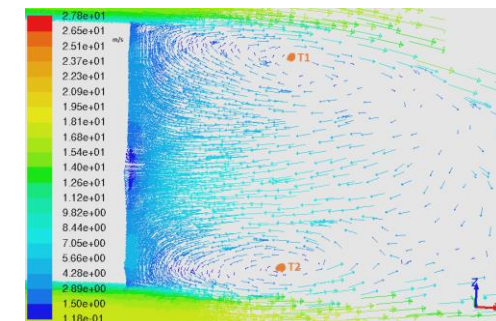

Fig. 2: Mean streamwise velocity fields in the wake of an Ahmed body

Romain RODRIGUEZ, Ph.D. Student in Fluid Mechanics, ESTACA'LAB, ESTACA, West Campus

Air quality and Depollution in transportation systems (automotive, aeronautical and railways)

Contact : [romain.rodriquez@estaca.fr](mailto:romain.rodriquez@estaca.fr)  
+33. (0)2 4359 5392



## Research topics :

Experimental study of the nanoparticle dispersion in the wake of Ahmed bodies (Fig.1)

- Velocity measurements with LDV system at ESTACA Laval
- Velocity measurements with PIV system at CORIA (Rouen, France)
- Particle number concentration measurements with ELPI system at ESTACA

## Examples of past projects :

- Experimental investigation (Fig.2) of a novel VTOL aircraft concept for operations in urban areas : force and pressure measurements (Internship, ISAE-ENSMA - Politecnico di Torino)
- Turbulence model evaluation (RANS, URANS, RANS-LES) for the numerical studies (Fig.3) of aerodynamics of road vehicles (Internship, ISAE-ENSMA - PSA Peugeot-Citroën)

## Collaborations (academic, institutional and industrial):

- CORIA (Rouen, France), IFSTTAR (Nantes, France)
- Airparif, PSA Peugeot-Citroën

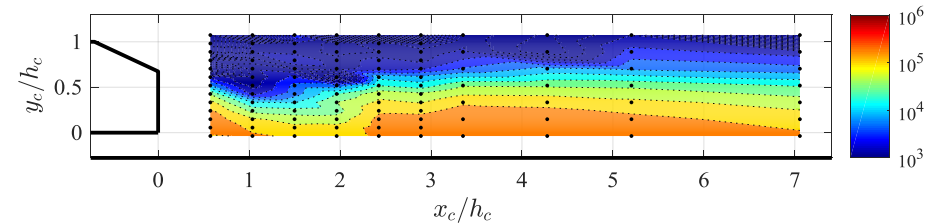

Fig.1 : Particle number concentration (symmetry plane) in the wake of Ahmed body 25° at  $Re_n=4,95.10^4$

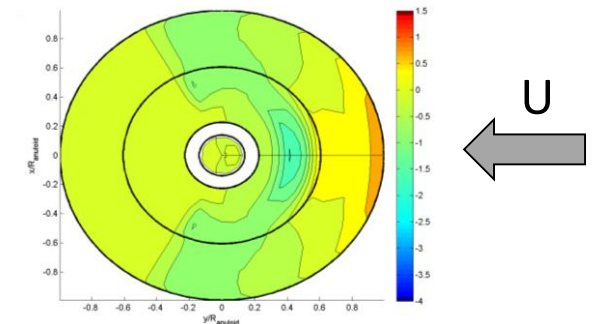

Fig.3 : Pressure coefficient distribution on the concept,  $Re=1,9.10^6$ , incidence  $-10^\circ$

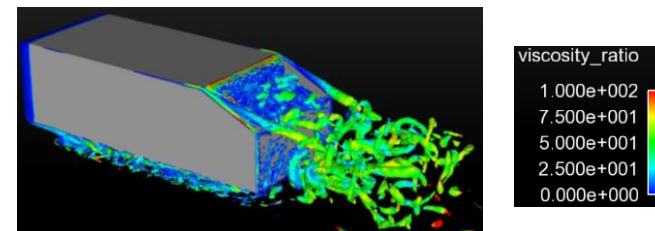
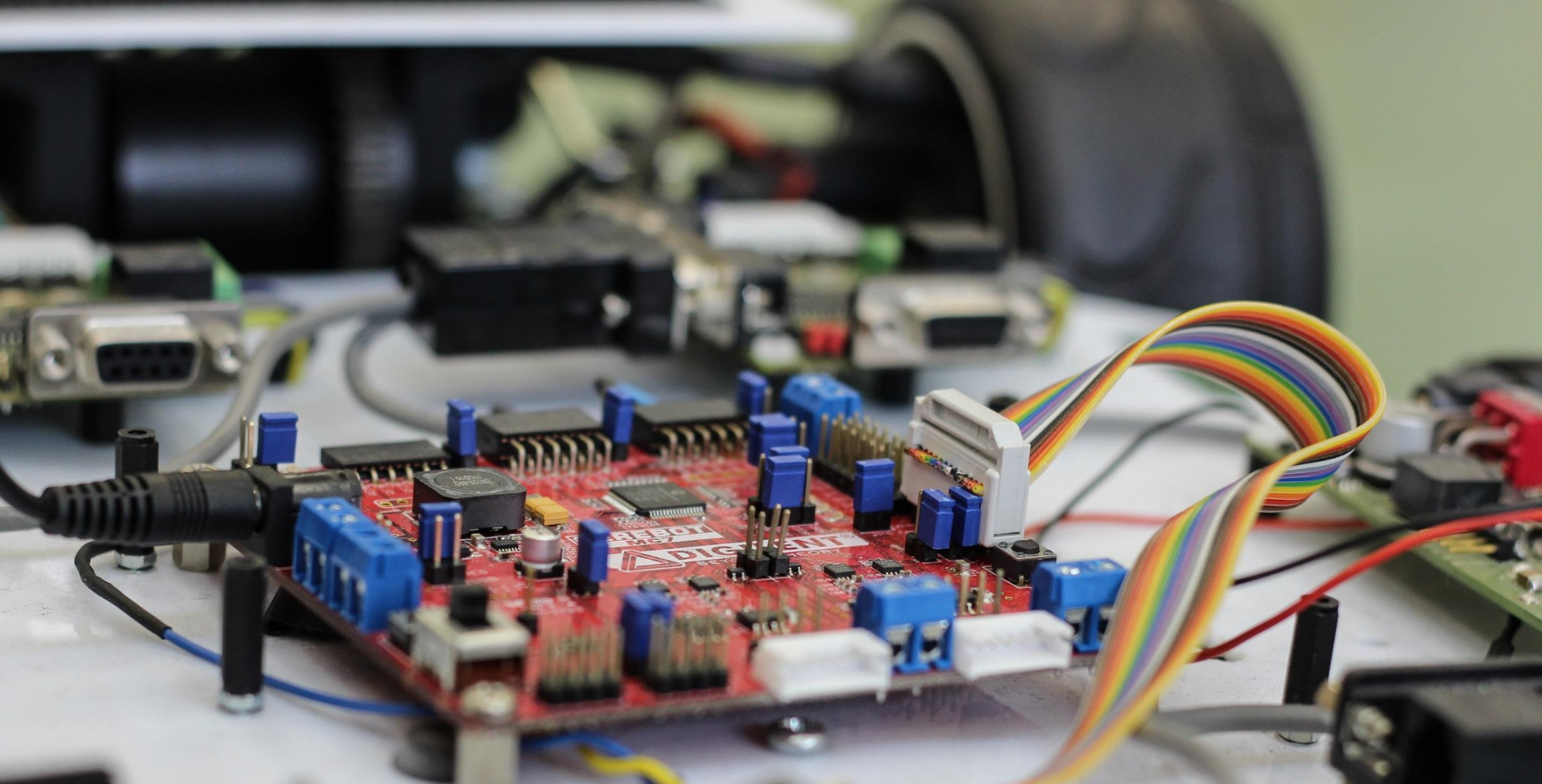

Fig.2 : iso  $Q$ -criterion= $4.10^5$  colored by the viscosity ratio in the wake of Ahmed body 25° at  $Re_n=7,3.10^5$  (SBES turbulence model)



Department of Energy  
and Embedded Systems

**ASSOCIATE PROFESSORS**

**Toufik AZIB, Ph.D. - Associate Professor of Electrical Engineering**

**Energy and Embedded Systems for Transportation Research Department (automotive, aeronautical and railways)**

**Contact :** toufik.azib@estaca.fr  
+33. (0) 1 76 52 11 03



## **Biographical note:**

Dr. Toufik AZIB received a Ph.D. in electrical engineering from the University of Paris South XI, France, in 2010. After receiving the Ph.D. degree, he joined the French Naval Academy Research Institute IRENAv where he was an Assistant Professor of electrical engineering. Since 2011, he has been with the Energy and Embedded Systems for Transportation Research Department from the Engineering Research Center ESTACA'LAB of ESTACA engineering school, France, where he is currently an Associate Professor of electrical engineering. His current research interests include optimal design of power electronics and mechatronics, and control /energy management of new electrical devices (Fuel cell, batteries and ultracapacitors) for automotive and aeronautics applications.

## **Equipment and Tools:**

- VHE, VE and FCVE platforms
- Renewable energy generator
- Interleaved converter and electrical machines test benches
- Matlab, PSIM, dSPACE (1104,1103, 1005).

## **Collaborations (industrial, academic and institutional):**

- PSA, Valeo, RENAULT, DPS, FAAR, DAMS, ...
- Universities of Paris Sud, Brest, Belfort, Paris 6, CentralSupélec, Supméca, UFAS (Algeria), UPC (Espagne), IRH (Canada), ...
- Ifsttar, Vedecom, ...



# Department of Energy and Embedded Systems

**Bertrand BARBEDETTE**, Associate Professor in Mechatronics, ESTACA'LAB, ESTACA, West Campus, PhD, University of Le Mans (1999)



Design of mechatronic systems applied to automotive, aeronautics and soft mobility

Contact : [bertrand.barbedette@estaca.fr](mailto:bertrand.barbedette@estaca.fr)  
+33 (0)2 4359 4728 / +33 (0)674 397 524

## Research topics and scientific/technological skills:

- Multiphysics Modelling Methodology
- Experimental mechatronics systems
- Mechatronics software expert : Simscape / LMS Imagine

## Examples of past projects :

- O2M (Mechatronic Modeling and Design Tools) : co-sponsored by two European Competitiveness Groups Mov'eo and System@tic. Provide a common platform for the design, simulation, and manufacture of mechatronic systems
- Flight controls, fly-by-wire, Airbus Helicopters

## Ongoing research projects :

- Methodology development for embedded software , Faar industries, PhD thesis (Fig. 1)
- Design methodology for mechatronic actuator in themomanagment, Mann + Hummel, PhD thesis (Fig. 2)
- Series hybrid archicture for e-bike, STEE, PhD thesis (Fig. 3)
- Karting for blind drivers, Altran research (internship)
- Mechatronics Lighting Systems in Automotive, ELS Chair

## Collaborations (academic, institutional and industrial):

- Universities of Paris Saclay, Centrale/Supelec, Lyon...
- VEDECOM, Institute of Otipics Graduate School, Strate Design College...
- Renault, PSA, Valeo, Mann+Hummel, Altran, STEE, Automotive Lighting, Dassault aviation, ...

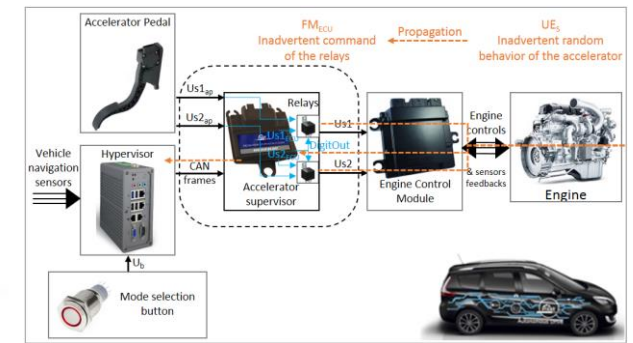

Fig. 1: Accelerator pedal use case for applying methodology



Fig. 2 : Test bench for an E-valve in Automotive

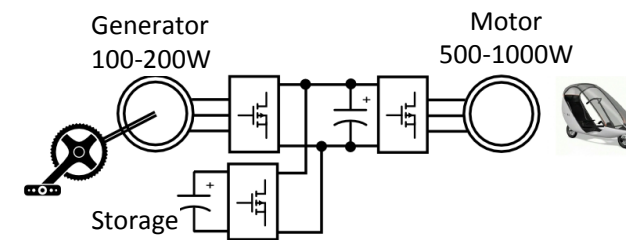

Fig. 3 : New hybrid architecture for e-bike

**Moussa BOUKHNIFER, Associate Professor HDR, Senior Member IEEE, ESTACA of Paris**



Contact : [moussa.boukhnifer@estaca.fr](mailto:moussa.boukhnifer@estaca.fr)  
+33 (0)1.76.52.11.13  
<https://www.estaca.fr/moussa.boukhnifer.html>

## Biographical note :

Moussa Boukhnifer is an Associate Professor HDR at ESTACA of Paris (France). He received the MSc degree in electrical engineering from Institut National des Sciences Appliquées de Lyon, Villeurbanne, France, in 2002 and the Ph.D. degree in control and engineering from the University of Orléans, Orléans, France in december 2005. He received the habilitation for heading research (HDR Habilitation à Diriger des Recherches) in december 2015 from Paris Sud University, France. His research interests include advanced control techniques, diagnosis and fault tolerant control of ac drives, renewable energy, electric powertrains, and autonomous vehicle.

Moussa Boukhnifer is the author of more than 100 national and international publications, senior member IEEE and editorial member of IJDSS, IJNDC and MECHATROJ International Journals.

## Main projets :

**O2M** (mechatronic modeling tools)

**CISACS** (new actuation concept of aircraft flight control systems)

**ICODE** (Institute for control and decision)

## Collaborations (academic, institutional and industrial) :

GeePs (CNRS), SATIE (CNRS), LSIS (CNRS), MIS, UL...

ENIS (Tunisie), USTHB (Algérie), Polytechnique de Milan (Italie)...

IFSTAAR, VEDECOM, ISL (Franco-Allemand), ...

Thales, Agenium, PSA, Renault, Valeo, Sagem...

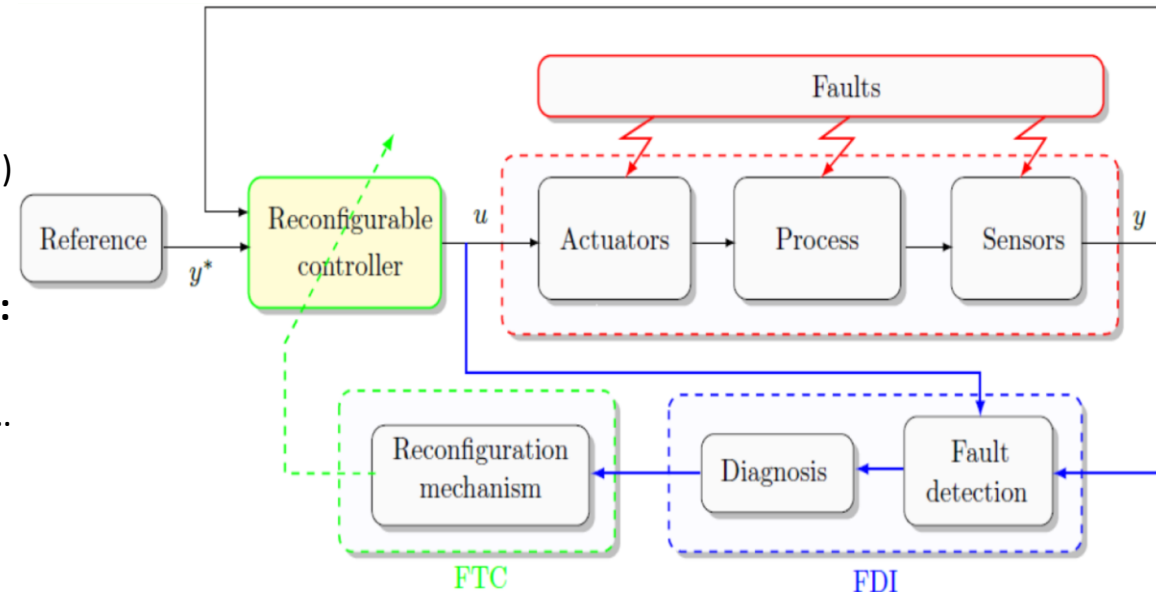

Fig 1. Fault Tolerant Control Scheme

Vincent JUDALET, Associate Professor in Computer Science, ESTACA'LAB, Paris-Saclay Campus, PhD, University of Evry (2016)

## Autonomous Driving and Road Users Intention Perception

Contact : [vincent.judalet@estaca.fr](mailto:vincent.judalet@estaca.fr)

+33. (0)1 7652 1204

<https://www.estaca.fr/vincent-judalet.html>

### Research topics :

- Road users intentions perception and prediction for the autonomous vehicles
- Risk assessment for the autonomous path planning and decision making
- Experimental investigations (test vehicles) and on-board measurements

### Ongoing research project :

- Road Users Safety and Autonomous Driving (funded by Fondation Sécurité Routière)

### Collaborations (academic, institutional and industrial):

- University of Queensland
- Vedecom, Ifsttar
- PSA, FAAR Industries, FEV

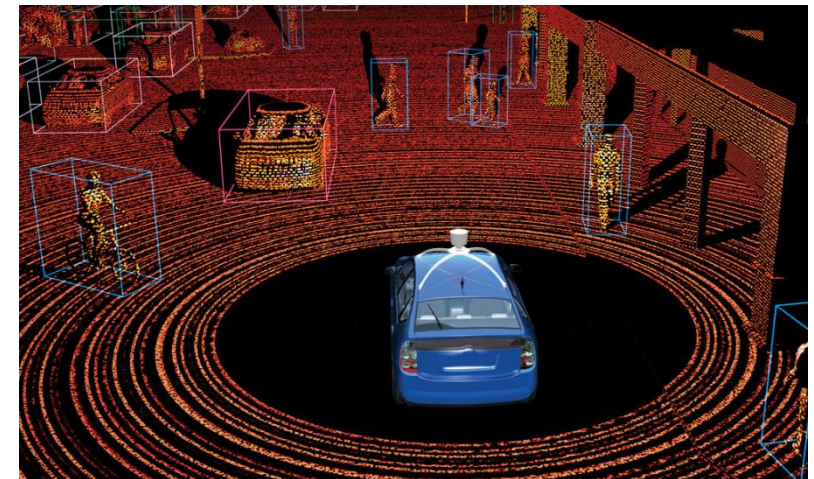

Fig. 1: road users perception with LIDAR sensor (source G. Murdoch/popular science)

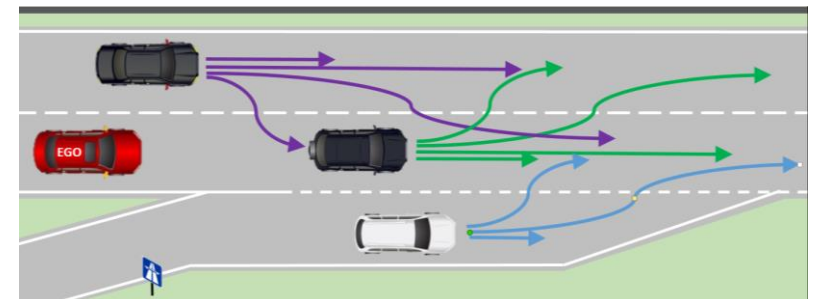

Fig. 2: Surrounding vehicles maneuvers prediction

Fouad KHENFRI, Associate Professor in Embedded Systems, ESTACA'LAB, ESTACA, West Campus, PhD, University of Nantes (2016)



Embedded system performance analysis and optimization

Contact : [fouad.khenfri@estaca.fr](mailto:fouad.khenfri@estaca.fr)

+33. (0)2 4359 4725

<https://www.estaca.fr/fouad-kenfri.html>

## Research topics :

- Embedded software design (drone, autonomous vehicle)
- Embedded system performance analysis and optimization for AUTOSAR E/E Architecture.
- Multi-objective optimisation (discrete and continuous domains)
- Advanced control for Non-Linear Systems (drone, vehicle)

## Examples of past projects :

- Hybrid Particle Swarm & Nelder–Mead (PSO–NM) optimization algorithm,
- Novel Heuristic Algorithm for Mapping AUTOSAR Runnables to Tasks
- Holistic Optimization Approach for the Synthesis of AUTOSAR E/E Architecture
- Framework for decision aid and optimization for AUTOSAR-compliant embedded systems (FREEDOM)
- Realization of an autonomous electric vehicle 1/10-scale

## Ongoing research projects :

- New version of the FREEDOM framework for decision aid and optimization
- Intelligent and connect light duty vehicle for the professional service (funded by GRUAU)
- Integration of decision-making functions into autonomous systems through a model-based approach
- Deep learning for autonomous driving (drone, vehicle)

## Collaborations (academic, institutional and industrial):

- INSA Strasbourg, Ecole Centrale de Lille, CDER Algeria, ...
- CEA, IRCCYN, ...
- GRUAU, NEXTEER, ...



Figure 1: Deep learning for autonomous driving

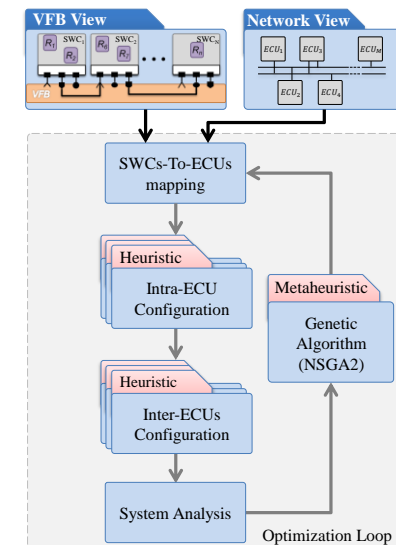

Figure 2: Embedded system performance analysis and optimization

# Department of Energy and Embedded Systems

**Cherif LAROUCI** : professor at ESTACA engineering school, Head of Energy and Embedded Systems for Transport research department of ESTACA'LAB, IEEE senior member

Contact : cherif.larouci@estaca.fr  
+33. (0)1 76 52 11 38



## Biographical note:

Cherif LAROUCI is professor at ESTACA engineering school. He received a Ph.D. in electrical engineering from the National Polytechnic Institute of Grenoble in 2002. In the same year, he joined ESTACA as an Assistant Professor. He was the head of ESTACA's Control and System laboratory between 2006 and 2013. He received the accreditation to supervise research (HDR degree) from Paris-Sud University in 2013. Currently, he is the head of Energy and Embedded Systems for Transport research department of ESTACA'LAB.

His research interests include modelling, design and optimization of power electronics converters for automotive, aeronautics, space and railway applications, optimization of mechatronic systems under multi-physical constraints, embedded energy management as well as reliability and fault tolerant control of embedded electrical systems.

## Publications:

- International Journals : 23
- Chapter Books: 4
- National journals: 7
- International Conferences: 75

## Supervision of Ph.D students:

- 5 defended theses
- 6 theses in progress
- 5 research masters
- Participation to 10 thesis defenses

## Main Industrial projects and collaborations:

- Main collaborative Projects: **O2M** (mechatronic modeling tools), **SOFRACI** (innovative structure of a high efficiency inverter including recharge function), **CISACS** (new actuation concept of aircraft flight control systems) , **MIME** (Integration of mechatronic systems)
- Main industrial collaborations: PSA, Renault, Valeo, GRUAU, FAAR Industry, Mann + Hummel, ALL4TEC, Dassault Aviation, SAFRAN group, Airbus group, AVL, STMicroelectronics

**Nassim RIZOUG, Associate Professor in Power electronic & energie storage system, ESTACA'LAB, ESTACA, West Campus, PhD, Ecole Centrale de Lille (2006)**

**Energy storage systems and power electronics for transportation**

Contact : [nassim.rizoug@estaca.fr](mailto:nassim.rizoug@estaca.fr)  
 +33. (0)2 4359 4726  
<https://www.estaca.fr/nassim-rizoug/>



### Research topics :

- Energy storage systems characterization (Batteries, ultracapacitors, fuel Cell, Photovoltaic, ...).
- Hybridization of energy sources (Battery-Battery, Fuel cell - battery, supercapacitor - fuel cell, ...).
- Power management strategies for energy storage systems.
- Power electronic systems for transportation.

### Examples of past projects :

- Supercapacitor characterization (funded by Schneider)
- Electrification of Light duty vehicle (Vueflex Project funded by BPI France).
- Sizing and management of hybrid storage system for an electric vehicle (funded by Mayenne local community).

### Ongoing research projects :

- Sizing and management of hybrid storage source (Fuel cell - Battery) for electric vehicle, PhD thesis.
- Intelligent and connect light duty vehicle for customer assistance (with Gruau)
- Minimum energy control for UAV system (trajectories optimisation), PhD thesis
- Batterie HP-Batterie HE hybrid source for electric vehicle, PhD thesis
- Optimisation of Total cost of ownership for electric vehicle. PhD thesis

### Collaborations (academic, institutional and industrial):

- University of bath UK, Ecole centrale de Lille, Université de Bordeaux, UTC
- Gruau, Renault, PSA, GYS, Airbus, ...

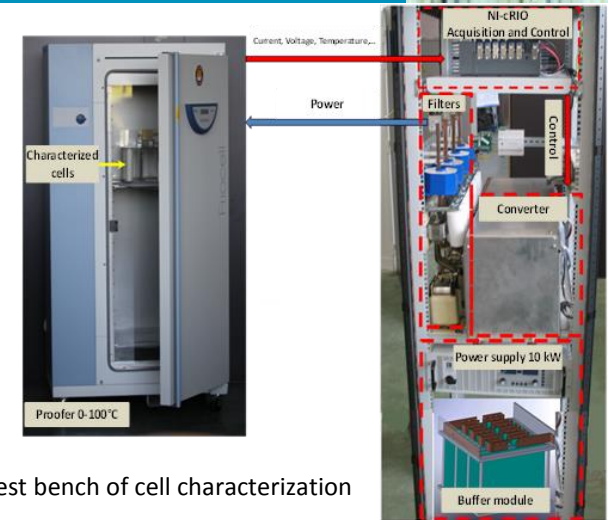

Fig. 1: Test bench of cell characterization

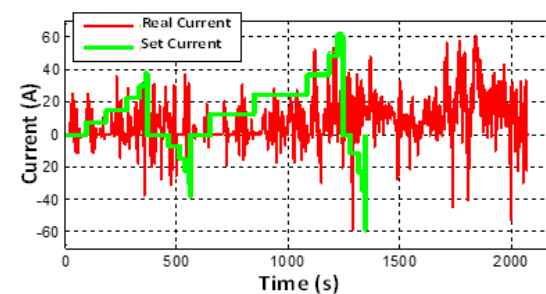

Fig. 3: Real and cycling currents

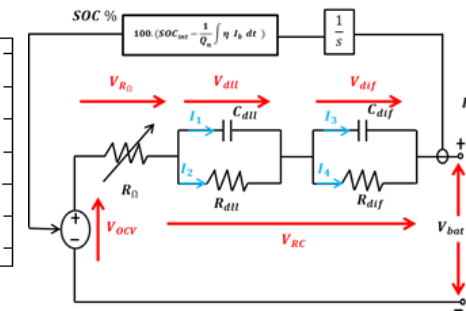

Fig. 2: Battery cell equivalent model

# Department of Energy and Embedded Systems

Dr Sébastien SAUDRAIS, Associate Professor in Embedded Systems, ESTACA'LAB, ESTACA

Computer science design and development in transportation systems (automotive, aeronautical and railways)

Contact :    sebastien.saudrais@estaca.fr  
              +33. (0)2 43 59 47 22  
              <https://www.estaca.fr/sebastien-saudrais/>



## Research topics :

- model driven engineering,
- quality properties along software development process,
- model at runtime.

## Examples of past supervised Phd :

- ORQA: a framework for the energy management in electric vehicles (B. Tchakaloff, 2011-2015)
- Verifying Design Properties at Runtime Using [Models@Run.Time](#) :Application to Autonomous Connected Vehicles (H. Loulou, 2014-2017)
- ALEBAS: embedded systems safety analysis and development methodology (J.Godot, 2014-2018 with Faar Industry)

## Ongoing research projects and Phd:

- Model-based testing integration in a software development process (H. Mhanna, 2015-... with ALL4Tec)
- Energy estimation and mission planning methodology for marine drone (DNG solution)
- Advanced Lighting Functions with High-Resolution Road Projection (with IOGS and ELS Chair)
- Model-driven engineering for transportation systems (MOST with CEA)

## Collaborations (academic, institutional and industrial):

- IOGS, Karlsruhe Institute of Technology, CENTRIA, UBO, ELS Chair
- CEREMA, CEA List (joined team), GIS ITS
- Faar Industry, DNG solution, ALL4Tec, SNCF,

# Energy and Embedded Systems for Transportation Research Department

Rabia SEHAB, Associate Professor in Control and Fault Diagnostics Systems, ESTACA'LAB, ESTACA, West Campus, Dr. Ir. Catholic University of Louvain, Louvain la neuve, Belgium (1997)

Control and Fault Diagnostics for Transportation Systems

Contact : [rabia.sehab@estaca.fr](mailto:rabia.sehab@estaca.fr)

+33. (0)2 4359 4727

<https://www.estaca.fr/rabia-sehab.html>



## Research topics :

Advanced control, software sensors, fault analysis, mechatronics at a scale system, Multiphysics modelling of transportation systems, control of electric machines for the emulation of transportation systems , real time control for the emulation of transportation systems

## Examples of past projects :

- Innovative concept of actuators for flight control of helicopters new generation. (PhD Thesis funded by Airbus Helicopters)
- Specific Electric vehicles : sizing, modelling, control design and energy recovery (Research Project funded by Valeo, Pôle O2M)
- Electric aircraft: Modelling and control for energy recovery ( Research Project supported by Airbus Group Innovation)

## Ongoing research projects :

- Advanced control, software sensors and fault analysis for electric vehicles using switched reluctance machines (SRM): Development and validation using a test bench. PhD thesis.
- Software sensors for headlight levelling systems: Development and experimental validation. ELS Chair project.
- Improving Quadrotor Reliability and Performance Using Switched Reluctance Machines. Cotutelle PhD thesis with Cranfield University.

## Collaborations (academic, institutional and industrial):

- GEEPs (SUPELEC), University of Paris Diderot
- ELS Chair (Valeo, Renault, PSA)
- Airbus Helicopters
- University of Cranfield, Aeronautical Research Center (UK)



SRM test bench

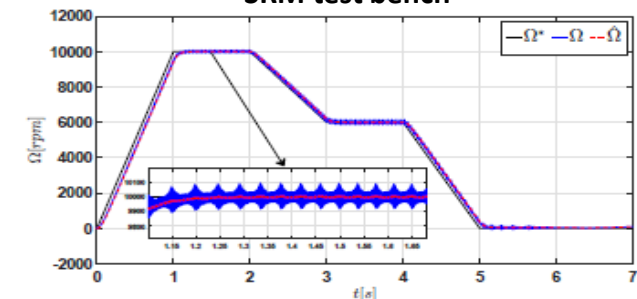

Estimation of the SRM velocity in an electric vehicle drivetrain using extended kalman filter <sup>B2</sup>



# Department of Energy and Embedded Systems

Hassan SOUBRA, Associate Professor in Embedded Software, ESTACA'LAB, PhD, University of Quebec (2011)

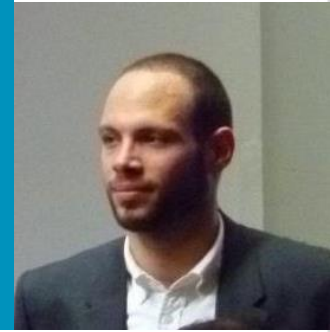

Embedded Software measurement and metrics (IoT, IoV, SmartCities...)

Contact : [hassan.soubra@estaca.fr](mailto:hassan.soubra@estaca.fr)  
+33. (0)1 76 52 11 62 - <https://www.estaca.fr/hassan-soubra.html>

## Research topics :

- Software metrics and measurements
- IoV, IoT and Smart cities
- COSMIC functional sizing

## Examples of past projects :

- Verification of security properties at runtime in the context of autonomous vehicles
- CPU load estimation in the context of AUTOSAR
- Development effort estimation using COSMIC

## Ongoing research projects :

- Internet of Vehicles
- Software measurement for reliability estimation in driverless cars

## Collaborations (academic, institutional and industrial):

- UVSQ Versailles, ETS Montreal...
- Vedecom
- Vector



[www.cosmic-sizing.org](http://www.cosmic-sizing.org)



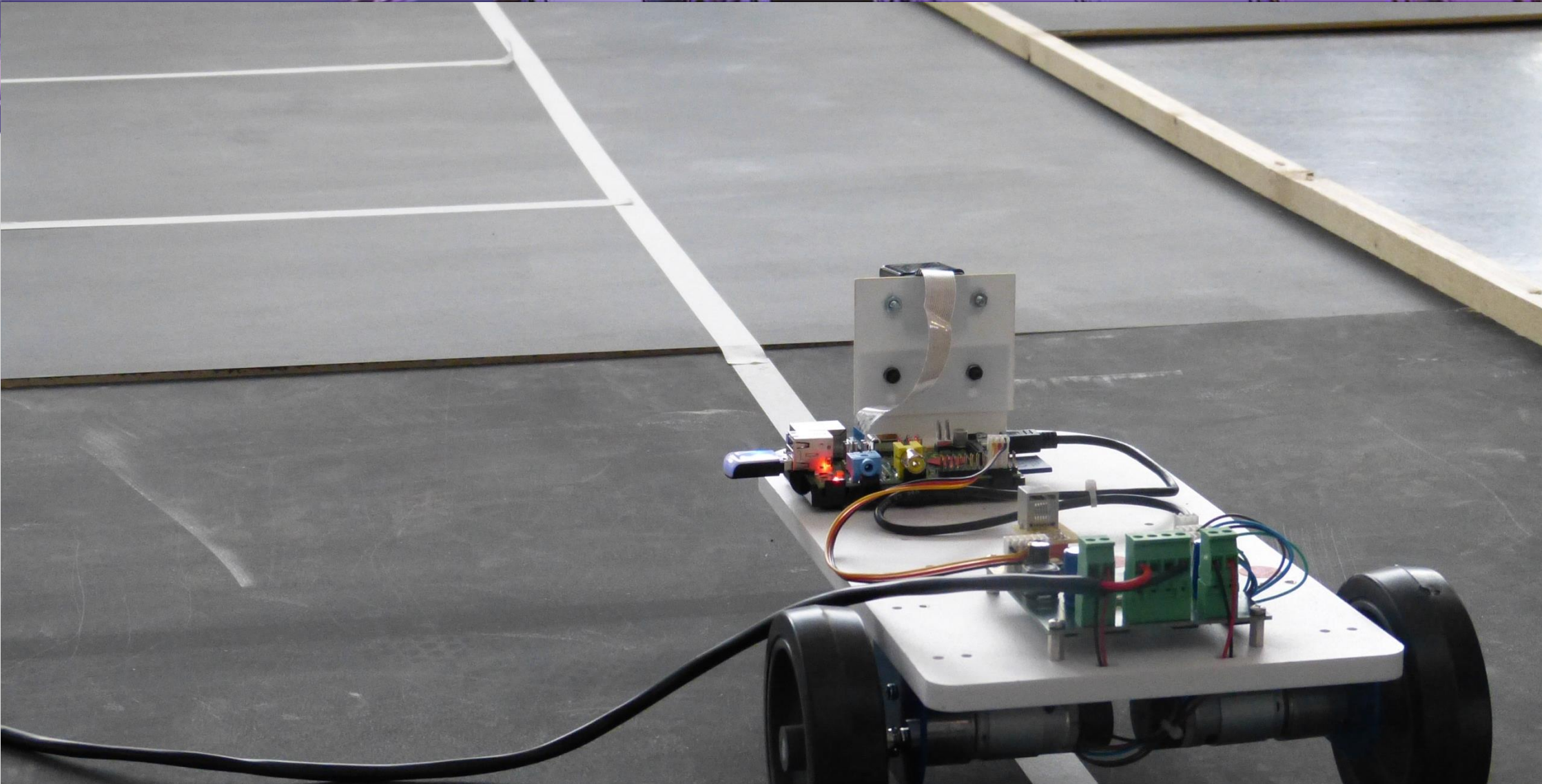

Department of Energy  
and Embedded Systems

**ONGOING PH.D. STUDENTS**

# Department of Energy and Embedded Systems

Anthony BABIN, PhD Student, ESTACA'LAB, ESTACA, West Campus

Sizing and management of energy storage systems (automotive, aeronautical and railways)

Contact: [anthony.babin@estaca.fr](mailto:anthony.babin@estaca.fr)  
+33 (0)2 43 59 53 94  
<https://www.estaca.fr/anthony-babin/>



## Research topics:

- Electric vehicle modeling, energy storage modeling (electrical, thermal and aging)
- Intelligent recharge strategy for electric vehicle, battery sizing, total cost of ownership optimization

## Research project:

- VUE-Flex: Flexible (Fig. 1) 3.5t light-duty commercial electric vehicle ; vehicle and battery modeling (Fig. 2 & 3), Total cost of ownership improvement : optimal battery sizing and intelligent recharge strategy (funded by BPI France)

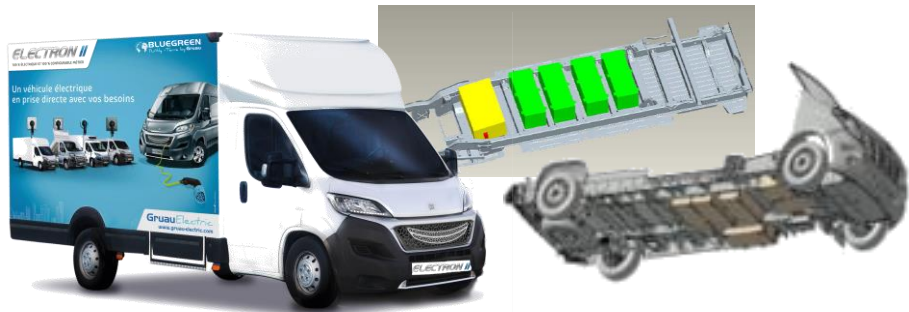

Fig. 1: Flexibility : modular battery integration

## Collaborations (academic, institutional and industrial):

- INP Toulouse (Laplace)
- CEA LITEN
- GRUAU, Actia automotive, Enedis...

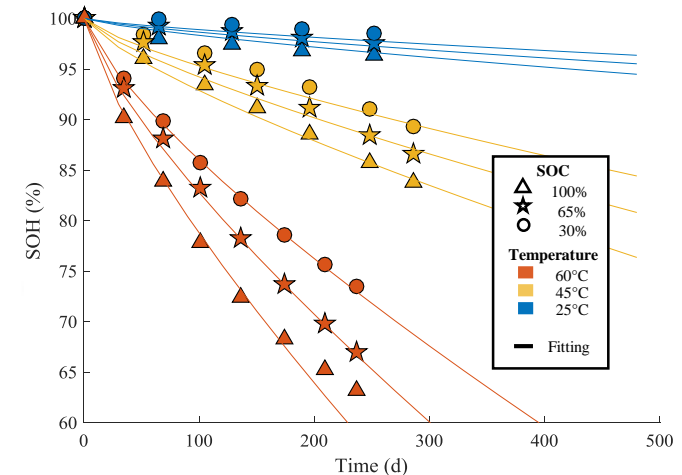

Fig. 2: Simulations and measures of calendar degradation of Li-ion cell

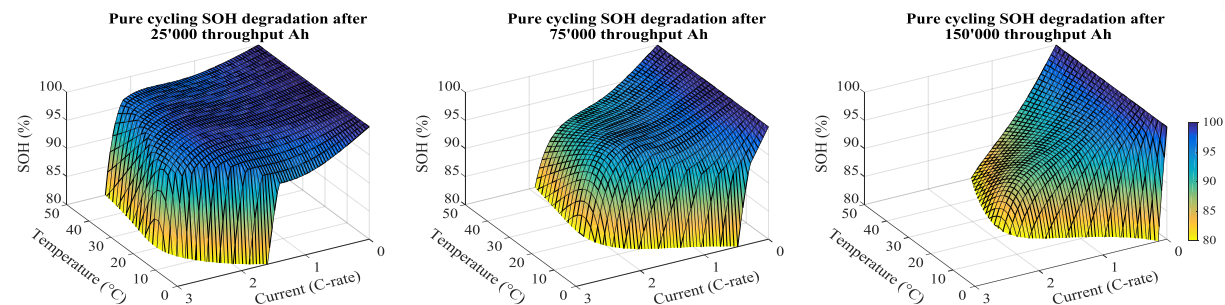
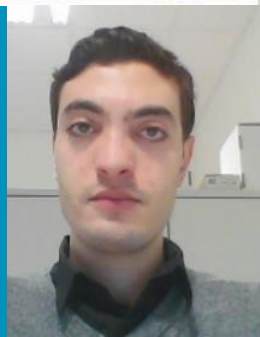

Fig. 3: Simulations of pure cycling degradation after 500, 1500 and 3000 cycles

Abdelmoudjib BENTERKI, Ph.D. Student  
Paris-Sud University / ESTACA Paris Saclay/ VEDECOM Institute

Thesis : Estimation of the road users intentions for the autonomous vehicle.  
Supervisors : M. BOUKHNIFER, V. JUDALET, C. MAAOUI.

Contact : [abdelmoudjib.benterki@estaca.fr](mailto:abdelmoudjib.benterki@estaca.fr), [www.benterki.me](http://www.benterki.me), +33 1 76 52 12 20.



## Research Interests

- Vehicles intention estimation and maneuver prediction.
- Trajectory planning for autonomous vehicles.
- Artificial intelligence for autonomous driving



## Ongoing research projects

- Developing methods for estimating the intentions of road users based on available information in an autonomous vehicle.
- Based on the past trajectory and the current dynamics of a target vehicle, we anticipate its probable trajectory during the next few seconds.
- Using the current results of artificial intelligence, we develop an efficient method for motion prediction.
- This work therefore includes a strong experimental component with measurement and implementation on the VeDeCom test vehicles.

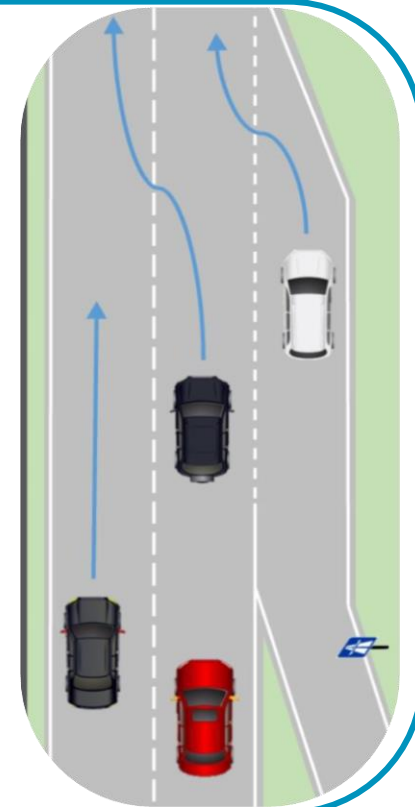

# Department of Energy and Embedded Systems

Mohamed Ryad BOUKHARI, Phd Student, 'VEDECOM' & 'ESTACA'LAB, ESTACA, Paris Saclay Campus'.

Fault-Tolerant Control Strategy for an Autonomous Vehicle Driving.

Contact : ryad.boukhari@vedecom.fr  
+33. (0)7 83 72 58 91

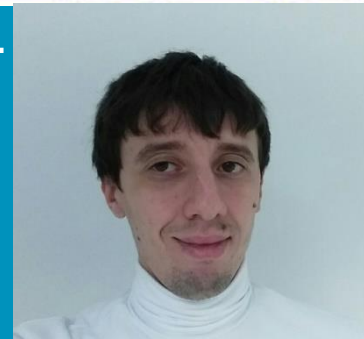

## Research context:

The recent advancement and deployment of 'advanced driving assistance systems (ADAS)' and 'autonomous vehicles' raises the question of safety of road users. In fact, a faulty sensor may jeopardize the vehicle stability.

## Ongoing works:

The idea is to develop a fault tolerant mechanism able to keep the vehicle safe even in faulty scenarios (Fig. 1). Several automation theory based algorithms are studied to perform fault tolerant perception and localization as : Maximum Likelihood Voting, History-Based Weighted Averga, Proportionnel and Integral Observer and Descriptor Observer.

To meet economic requirements, the future developed algorithms must decrease the hardware redundancy and the time burden, the idea of Integrated Multiple Model will be explored.

Materials of experimental validation made available by the VEDECOM Institute, represented by a Reanault Zoe autonomous demonstrator.



Fig.2: The VEDECOM Demonstrator



Fig. 1 : Fault Tolerant Control for autonomous vehicle

Laid DEGAA, PhD Student, ESTACA'LAB, ESTACA, West Campus

Energy storage systems and power electronics for transportation

Contact : [laid.degaa@estaca.fr](mailto:laid.degaa@estaca.fr)



## Biographical note:

Laid DEGAA received an engineering degree from the University of ENST, Algeria, in 2015. After receiving the Engineering degree, He started his phd studies in 2016 at the Energy and Embedded Systems for Transportation Research Department from the Engineering Research Center ESTACA'LAB of ESTACA engineering school, France



## Research topics :

- Energy storage systems characterization (Batteries, ultracapacitors, fuel Cell, Photovoltaic, ...).
- Hybridization of energy sources (Battery-Battery, Fuel cell - battery, supercapacitor - fuel cell, ...).
- Energy Management for the hybrid energy systems

## Collaborations (academic, institutional and industrial):

- Universities of Sousse, Brest, ENPO, ...
- IRDL, CDTA..

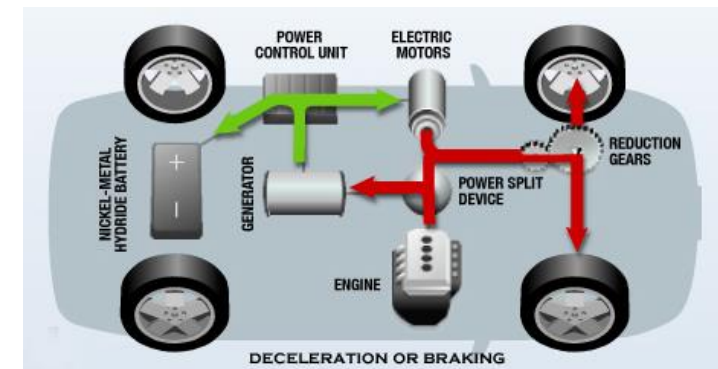

Fig. hybrid electric vehicle

# Department of Energy and Embedded Systems

**Montassar KHAMMASSI, Ph.D. Student in Robotics, Mechanical Design Engineer**

**Energy and Embedded Systems for Transportation Research Department (automotive, aeronautical and railways)**

**Contact :** [montassar.khammassi@estaca.fr](mailto:montassar.khammassi@estaca.fr)  
+33. (0) 1 76 52 11 27



## **Biographical note:**

Montassar KHAMMASSI received an engineering degree from the University of ENSIT, Tunisia, in 2014 with highest honors. After receiving the Engineering degree, he joined the Energy and Embedded Systems for Transportation Research Department from the Engineering Research Center ESTACA'LAB of ESTACA engineering school, France, in order to work in an industrial collaboration with MANN+HUMMEL in the framework of his PhD thesis on mechatronic systems. His current research interests include design Optimization of mechanical and mechatronic systems, for automotive and aeronautics applications.

## **Equipment and Tools:**

- Thermal management test bench of MANN+HUMMEL.
- Matlab/Simscape, dSPACE, National Instrument, CATIA, SolidWorks, C++.

## **Collaborations (industrial, academic and institutional):**

- MANN+HUMMEL

Chedia LATRECH, Postdoctoral Researcher, ESTACA'LAB, ESTACA, Paris-Saclay Campus, PhD, University of Amiens (2015)

Development of vehicle platooning control strategies

Contact : [chedia.latrech@estaca.fr](mailto:chedia.latrech@estaca.fr)

+33. (0)7 87331331

[https://scholar.google.fr/citations?user=jKFWV\\_8AAAAJ&hl=fr](https://scholar.google.fr/citations?user=jKFWV_8AAAAJ&hl=fr)[https://www.researchgate.net/profile/Chadia\\_Latrach](https://www.researchgate.net/profile/Chadia_Latrach)



## Research topics :

- Networked control, decentralised control strategy, conception and validation of platooning algorithms
- Linear and non-linear systems, lateral and longitudinal behaviour control, individual and string stability
- Assurate the stability and the security of convoy and the comfort of passengers

## Examples of past projects :

- Modeling the nonlinear model described by the side slip, roll and yaw motions
- Networked Fuzzy Control for Vehicle Lateral Dynamic with Limited Communication
- $H_\infty$  observer-based decentralised fuzzy control design for nonlinear interconnected systems: an application to vehicle dynamics

## Ongoing research projects :

- Modeling of an urban vehicle platoon
- Development of platooning control strategies

## Collaborations (academic, institutional and industrial):

- VEDECOM Versailles
- Assitant lecturer - research and teaching (ATER) at CentraleSupélec, Rennes, France

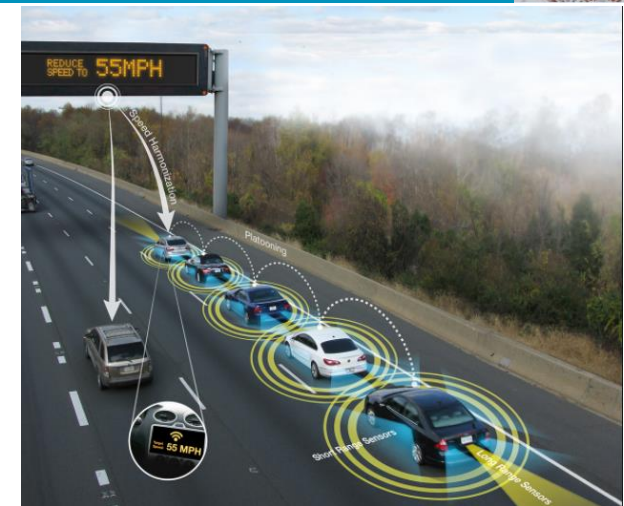

Fig. 1: Platooning

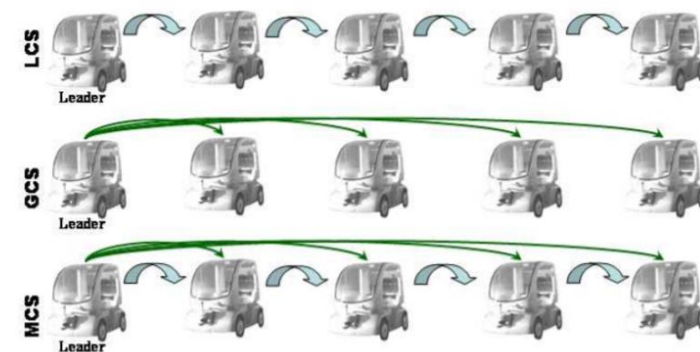

Fig. 2: Control Strategies for vehicle platooning



# Department of Energy and Embedded Systems

Jianwen MENG, 1st year PhD Student, ESTACA and Université Paris-Sud

Diagnosis and fault tolerant control (FTC) of a power train system of the electrical vehicle with the presence of electrical and mechanical faults

Directors : Moussa BOUKHNIFER, Enseignant Chercheur HDR, ESTACA      Demba DIALLO, Full Professor, Université Paris Sud - IUT de Cachan

Contact : [jianwen.MENG@estaca.fr](mailto:jianwen.MENG@estaca.fr)



## Research topics :

- Diagnosis and Fault Tolerant Control (FTC)
- Energy Management for the hybrid energy systems

## Examples of past projects :

- Nonlinear filtering with adaptive estimation of state transfer matrix for nonlinear systems with multiplicative noise, Shanghai Maritime University, Shanghai, China
- Multi-physical Modelling of A Brake Energy Recovery System of A Light Urban Vehicle, Université de Nantes, Saint-Nazaire, France

## Ongoing research projects :

- Fault tolerant control and energy management for the hybrid energy system which is applied for the electrical vehicles. Considering the ageing process or the faults in the energy systems (fuel cells and batteries/supercapacitors), the appropriate control/design strategies will be proposed based on the former work of our team (control and diagnosis system), especially in the domain of FTC robust control.

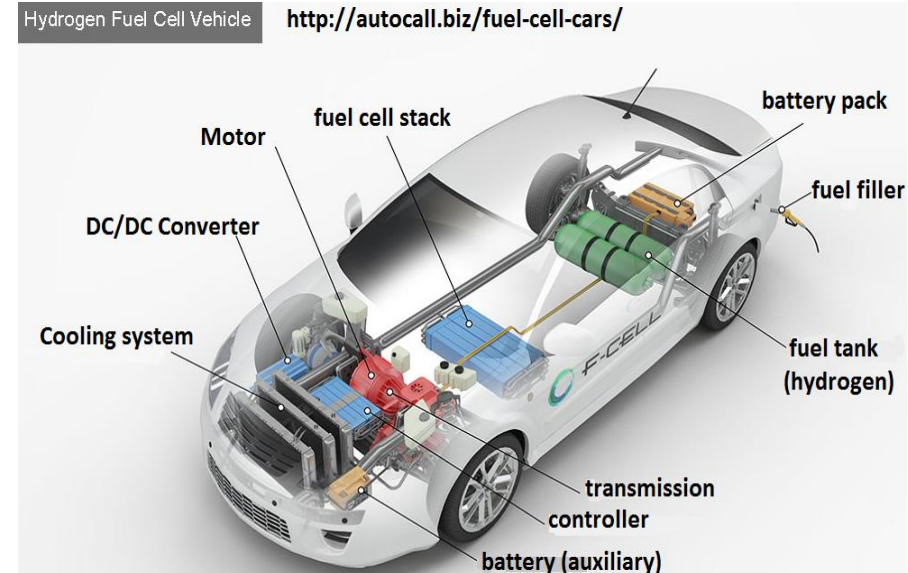

Ref : Oubellil R., Boukhnifer M., Fault tolerant control of energy management system for an electrical vehicle, Electromotion Journal, Vol. 22, 2015



**Yakoub SAADI, PhD student**

**ESTACA'LAB / GeePs / Paris-Sud university**

**Thesis title: Control strategies and fault analysis of a switched reluctance machine for an electric powertrain application.**

**Contact : yakoub.saadi@estaca.fr +33 (0) 7 545 348 78**

### Research topics:

- Switched Reluctance Machine's control and its integration in powertrain application
- Nonlinear and robust control
- Observers design
- Fault Detection and Diagnosis (FDD)
- Fault Tolerant Control (FTC)

### Goals :

- Robust control of the Switched Reluctance Machine (SRM) for the electric vehicle application taking into account the constraints imposed by the electrical traction applications
- Design and implementation of observer-based sensorless control algorithms of an Electric Vehicle propelled by a Switched Reluctance Machine with known and unknown load torque
- The development of one or more monitoring strategies for the automatic detection and diagnosis of the electrical faults in an Electric Vehicle propelled by a Switched Reluctance Machine followed by a reconfiguration strategy of the control according to the identified faults

### Thesis supervision:

- Pr. Demba DIALLO, GeePs
- Dr. Rabia SEHAB, ESTACA'LAB
- Dr. Ahmed CHAIBET, ESTACA'LAB
- Dr. Moussa BOUKHNIFER, ESTACA'LAB

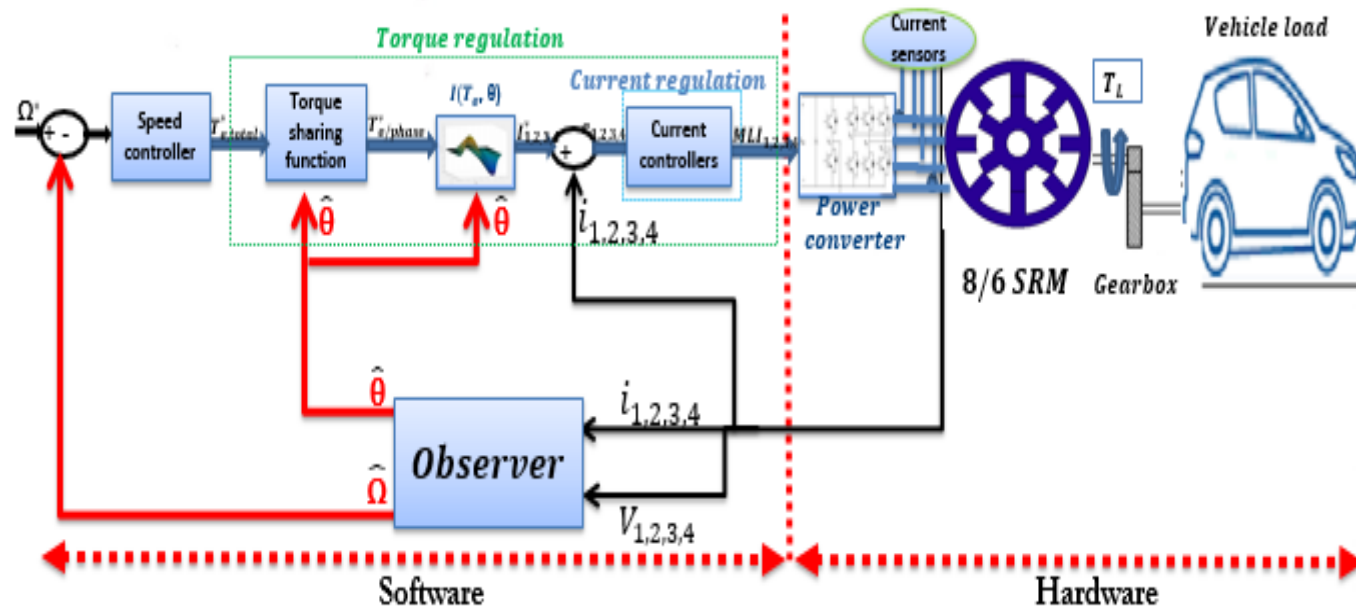

Implementation of the observer in the vehicle drivetrain propelled by a Switched Reluctance Machine